

600V N-Channel MOSFET GENERAL DESCRIPTION

This Power MOSFET is produced using advanced planar stripe DMOS technology. This latest technology has been especially designed to minimize on-state resistance, Have a high rugged avalanche characteristics. These devices are well suited for high efficiency switched mode power supplies, active power factor correction. electronic lamp ballasts based on half bridge topology.

| | | |
|-----------|--------------|-------|
| V_{DSS} | $R_{DS(ON)}$ | I_D |
| 600V | 1.3Ω | 7A |

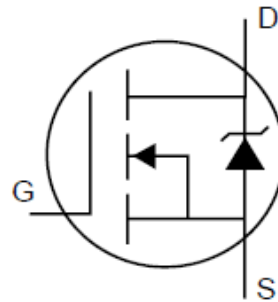
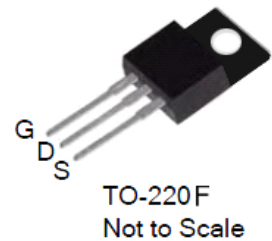
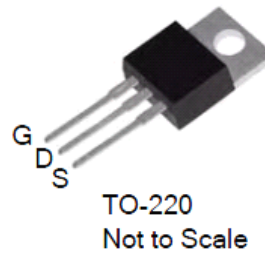

Features

- 7A, 600V, $R_{DS(on)} = 1.3\Omega$ @ $V_{GS} = 10V$
- Low gate charge (typical 29nC)
- Fast switching
- 100% avalanche tested
- Improved dv/dt capability

Ordering Information

| PART NUMBER | PACKAGE | BRAND |
|-------------|-------------|-------|
| 7N60/7N60F | TO-220/220F | 0GFD |

Absolute Maximum Ratings

TC = 25°C unless otherwise noted

| Symbol | Parameter | 7N60 | 7N60F | Units |
|-----------------------------------|--|-------------|-------|-------|
| V _{DSS} | Drain-Source Voltage | 600 | | V |
| I _D | Drain Current - Continuous (TC = 25°C) - Continuous (TC = 100°C) | 7.0 | 7.0 | A |
| | | 4.2 | 4.2 | A |
| I _{DM} | Drain Current- Pulsed (Note 1) | 28 | 28 | A |
| V _{GSS} | Gate-Source Voltage | ± 30 | | V |
| E _{AS} | Single Pulsed Avalanche Energy (Note 2) | 245 | | mJ |
| E _{AR} | Repetitive Avalanche Energy (Note 1) | 14.7 | | mJ |
| dv/dt | Peak Diode Recovery dv/dt (Note 3) | 4.5 | | V/ns |
| P _D | Power Dissipation (TC = 25°C) | 147 | 48 | W |
| | Derate above 25°C | 1.17 | 0.38 | W/°C |
| T _J , T _{STG} | Operating and Storage Temperature Range | -55 to +150 | | °C |
| T _L | Maximum lead temperature for soldering purposes, 1/8" from case for 5 seconds | 300 | | °C |

Thermal Characteristics

| Symbol | Parameter | 7N60 | 7N60F | Units |
|------------------|---|------|-------|-------|
| R _{θJC} | Thermal Resistance, Junction-to-Case | 0.85 | 2.6 | °C/W |
| R _{θCS} | Thermal Resistance, Case-to-Sink Typ. | 0.5 | -- | °C/W |
| R _{θJA} | Thermal Resistance, Junction-to-Ambient | 62.5 | 62.5 | °C/W |

Electrical Characteristics

TC = 25°C unless otherwise noted

| Symbol | Parameter | Test Conditions | Min | Typ | Max | Units |
|--------|-----------|-----------------|-----|-----|-----|-------|
|--------|-----------|-----------------|-----|-----|-----|-------|

Off Characteristics

| | | | | | | |
|-------------------------------------|---|---|-----|-----|------|------|
| BV _{DSS} | Drain-Source Breakdown Voltage | V _{GS} = 0 V, I _D = 250 μA | 600 | -- | -- | V |
| ΔBV _{DSS} /ΔT _J | Breakdown Voltage Temperature Coefficient | I _D = 250 μA, Referenced to 25°C | -- | 0.7 | -- | V/°C |
| I _{DSS} | Zero Gate Voltage Drain Current | V _{DS} = 600 V, V _{GS} = 0 V | -- | -- | 1 | μA |
| | | V _{DS} = 480 V, T _C = 125°C | -- | -- | 10 | μA |
| I _{GSSF} | Gate-Body Leakage Current, Forward | V _{GS} = 30 V, V _{DS} = 0 V | -- | -- | 100 | nA |
| I _{GSSR} | Gate-Body Leakage Current, Reverse | V _{GS} = -30 V, V _{DS} = 0 V | -- | -- | -100 | nA |

On Characteristics

| | | | | | | |
|---------------------|-----------------------------------|---|-----|------|-----|---|
| V _{GS(th)} | Gate Threshold Voltage | V _{DS} = V _{GS} , I _D = 250 μA | 2.0 | -- | 4.5 | V |
| R _{DS(on)} | Static Drain-Source On-Resistance | V _{GS} = 10 V, I _D = 3.5 A | -- | 1.05 | 1.3 | Ω |

Dynamic Characteristics

| | | | | | | |
|------------------|------------------------------|---|----|------|----|----|
| C _{iss} | Input Capacitance | V _{DS} = 25 V, V _{GS} = 0 V, f = 1.0 MHz | -- | 1000 | -- | pF |
| C _{oss} | Output Capacitance | | -- | 110 | -- | pF |
| C _{rss} | Reverse Transfer Capacitance | | -- | 12.6 | -- | pF |

Switching Characteristics

| | | | | | | |
|--------------|---------------------|--|-------------|-----|------|----|
| $t_{d(on)}$ | Turn-On Delay Time | $V_{DD} = 300\text{ V}, I_D = 7\text{ A},$ $R_G = 25\ \Omega$ | -- | 20 | -- | ns |
| t_r | Turn-On Rise Time | | -- | 50 | -- | ns |
| $t_{d(off)}$ | Turn-Off Delay Time | | -- | 80 | -- | ns |
| t_f | Turn-Off Fall Time | | (Note 4, 5) | -- | 70 | -- |
| Q_g | Total Gate Charge | $V_{DS} = 480\text{ V}, I_D = 7\text{ A},$ $V_{GS} = 10\text{ V}$ | -- | 29 | -- | nC |
| Q_{gs} | Gate-Source Charge | | -- | 4.7 | -- | nC |
| Q_{gd} | Gate-Drain Charge | | (Note 4, 5) | -- | 12.5 | -- |

Drain-Source Diode Characteristics and Maximum Ratings

| | | | | | | |
|----------|---|--|----------|-----|-----|----|
| I_S | Maximum Continuous Drain-Source Diode Forward Current | | -- | -- | 7.0 | A |
| I_{SM} | Maximum Pulsed Drain-Source Diode Forward Current | | -- | -- | 28 | A |
| V_{SD} | Drain-Source Diode Forward Voltage | $V_{GS} = 0\text{ V}, I_S = 7\text{ A}$ | -- | -- | 1.5 | V |
| t_{rr} | Reverse Recovery Time | $V_{GS} = 0\text{ V}, I_S = 7\text{ A},$ $di_F / dt = 100\text{ A}/\mu\text{s}$ | -- | 320 | -- | ns |
| Q_{rr} | Reverse Recovery Charge | | (Note 4) | -- | 3.0 | -- |

Notes:

1. Repetitive Rating : Pulse width limited by maximum junction temperature
2. $L = 10\text{ mH}, I_{AS} = 7\text{ A}, V_{DD} = 50\text{ V}, R_G = 25\ \Omega,$ Starting $T_J = 25^\circ\text{C}$
3. $I_{SD} \leq 7\text{ A}, di/dt \leq 200\text{ A}/\mu\text{s}, V_{DD} \leq BVDSS,$ Starting $T_J = 25^\circ\text{C}$
4. Pulse Test : Pulse width $\leq 300\ \mu\text{s},$ Duty cycle $\leq 2\%$
5. Essentially independent of operating temperature

Typical Characteristics

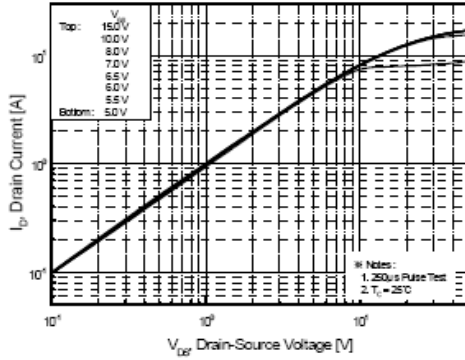

Figure 1. On-Region Characteristics

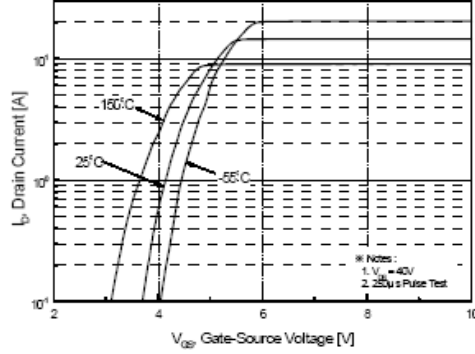

Figure 2. Transfer Characteristics

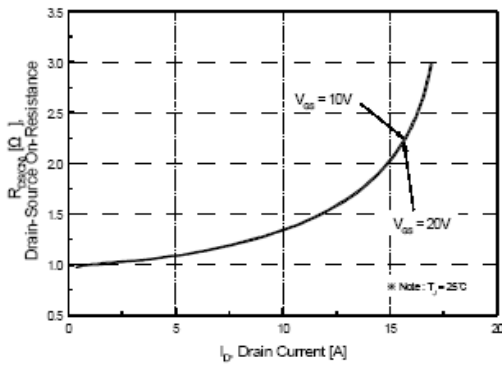

Figure 3. On-Resistance Variation vs Drain Current and Gate Voltage

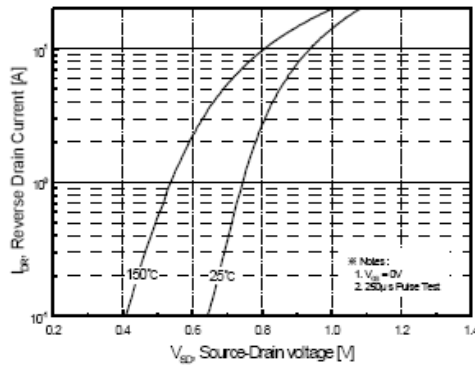

Figure 4. Body Diode Forward Voltage Variation with Source Current and Temperature

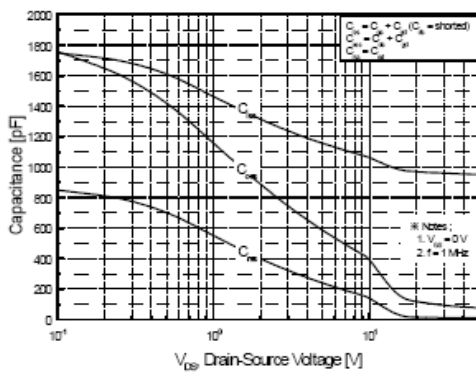

Figure 5. Capacitance Characteristics

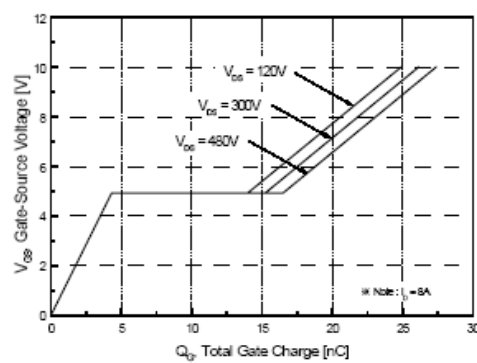

Figure 6. Gate Charge Characteristics

Typical Characteristics (Continued)

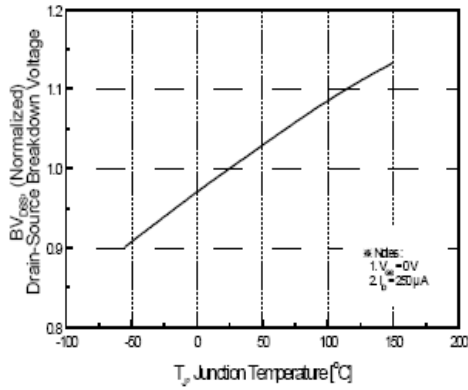

Figure 7. Breakdown Voltage Variation vs Temperature

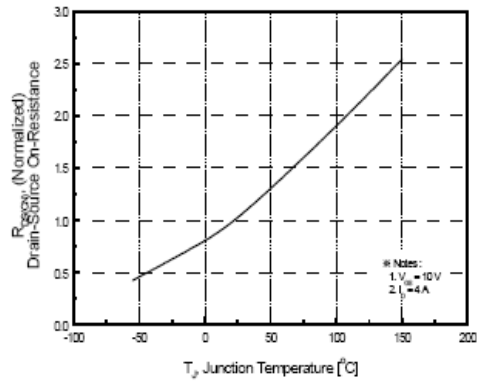

Figure 8. On-Resistance Variation vs Temperature

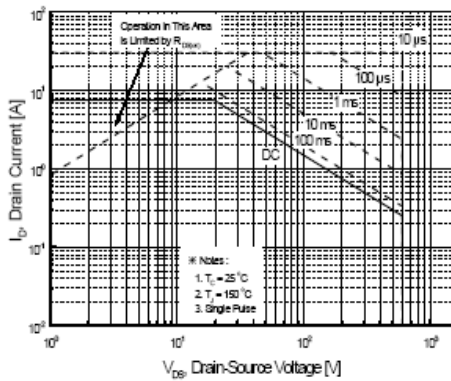

Figure 9-1. Maximum Safe Operating Area for TSP7N60M

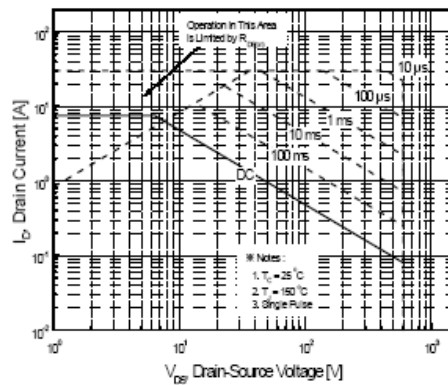

Figure 9-2. Maximum Safe Operating Area for TSF7N60M

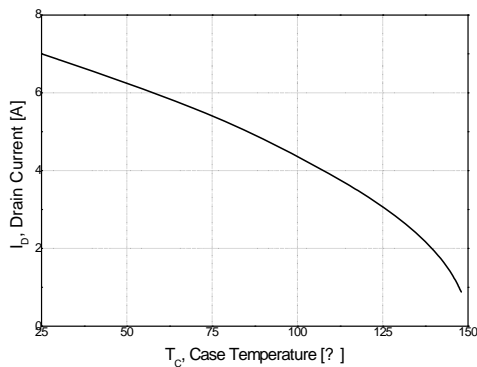

Figure 10. Maximum Drain Current vs Case Temperature

Typical Characteristics (Continued)

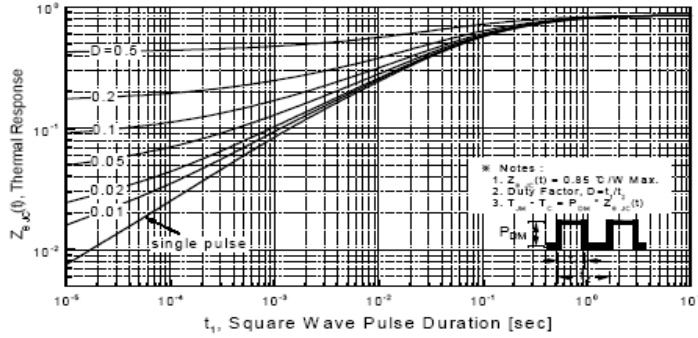

Figure 11-1. Transient Thermal Response Curve for TSP7N60M

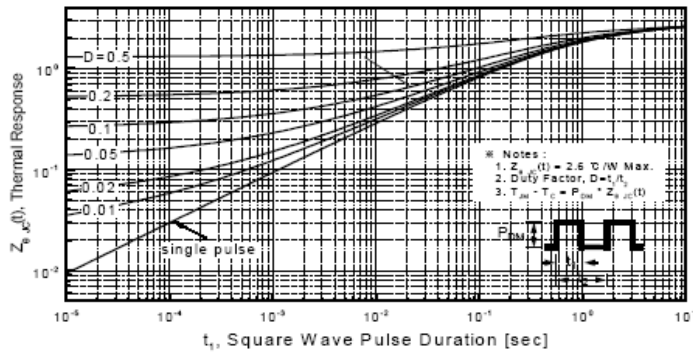
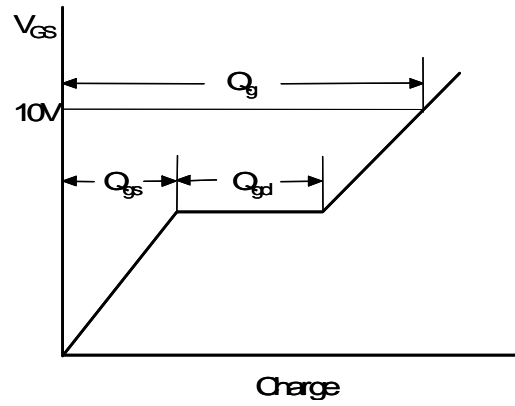
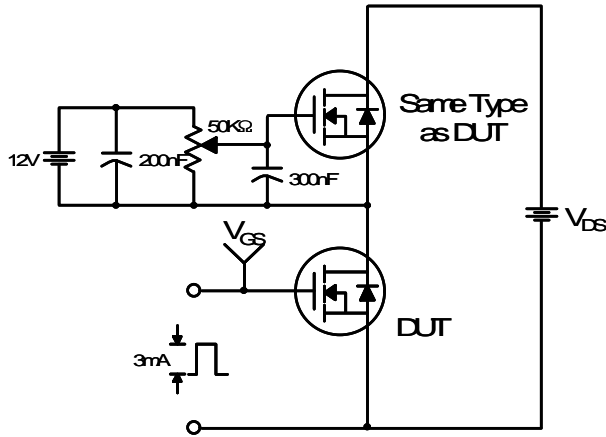
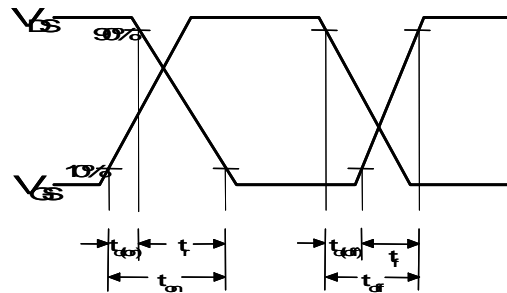
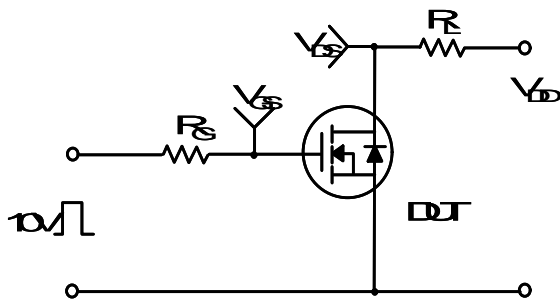

Figure 11-2. Transient Thermal Response Curve for TSF7N60M

Gate Charge Test Circuit & Waveform



Resistive Switching Test Circuit & Waveforms



Unclamped Inductive Switching Test Circuit & Waveforms

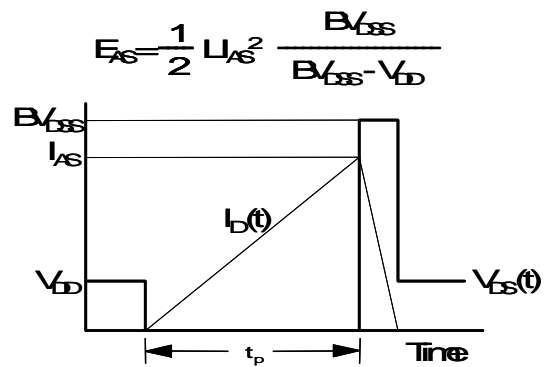
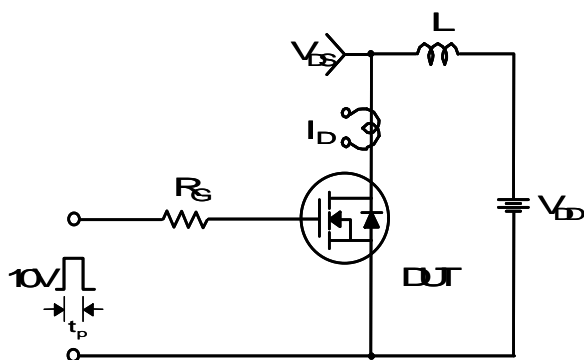

Peak Diode Recovery dv/dt Test Circuit & Waveforms

